

## Description

**Arduino® Nano** is an intelligent development board designed for building faster prototypes with the smallest dimension. Arduino Nano being the oldest member of the Nano family, provides enough interfaces for your breadboard-friendly applications. At the heart of the board is **ATmega328 microcontroller** clocked at a frequency of 16 MHz featuring more or less the same functionalities as the Arduino® Duemilanove. The board offers 20 digital input/output pins, 8 analog pins, and a mini-USB port.

## Target Areas

Maker, Security, Environmental, Robotics and Control Systems



## Features

- **ATmega328** Microcontroller
  - High-performance low-power 8-bit processor
  - Achieve up to 16 MIPS for 16 MHz clock frequency
  - 32 kB of which 2 KB used by bootloader
  - 2 kB internal SRAM
  - 1 kB EEPROM
  - 32 x 8 General Purpose Working Registers
  - Real Time Counter with Separate Oscillator
  - Six PWM Channels
  - Programmable Serial USART
  - Master/Slave SPI Serial Interface
- **Power**
  - Mini-B USB connection
  - 7-15V unregulated external power supply (pin 30)
  - 5V regulated external power supply (pin 27)
- **Sleep Modes**
  - Idle
  - ADC Noise Reduction
  - Power-save
  - Power-down
  - Standby
  - Extended Standby
- **I/O**
  - 20 Digital
  - 8 Analog
  - 6 PWM Output



# Contents

<b>1 The Board</b>	<b>5</b>
1.1 Application Examples	5
1.2 Accessories	5
1.3 Related Products	5
<b>2 Ratings</b>	<b>6</b>
2.1 Recommended Operating Conditions	6
2.2 Power Consumption	6
<b>3 Functional Overview</b>	<b>6</b>
3.1 Block Diagram	6
3.2 Processor	8
3.3 Power Tree	8
<b>4 Board Operation</b>	<b>9</b>
4.1 Getting Started - IDE	9
4.2 Getting Started - Arduino Cloud Editor	9
4.3 Sample Sketches	9
4.4 Online Resources	9
<b>5 Connector Pinouts</b>	<b>10</b>
5.1 Analog	11
5.2 Digital	11
5.3 ATmega328	12
<b>6 Mechanical Information</b>	<b>12</b>
<b>7 Certifications</b>	<b>13</b>
7.1 Declaration of Conformity CE DoC (EU)	13
7.2 Declaration of Conformity to EU RoHS & REACH 211 01/19/2021	13
7.3 Conflict Minerals Declaration	14
7.4 FCC Caution	14
<b>8 Company Information</b>	<b>15</b>
<b>9 Reference Documentation</b>	<b>15</b>
<b>10 Revision History</b>	<b>15</b>
<b>11 电路板简介</b>	
11.1 应用示例	
11.2 配件	
11.3 相关产品	

**12 额定值**

12.1 建议运行条件

12.2 功耗

**13 功能概述**

13.1 方框图

13.2 处理器

13.3 电源树

**14 电路板操作**

14.1 入门指南 - IDE

14.2 入门指南 - Arduino Cloud Editor

14.3 示例程序

14.4 在线资源

**15 连接器引脚布局**

15.1 模拟

15.2 数字

15.3 ATmega328

23

**16 机械层信息****17 认证**

17.1 符合性声明 CE DoC (欧盟)

17.2 声明符合欧盟 RoHS 和 REACH 211 01/19/2021

17.3 冲突矿产声明

17.4 FCC 警告

**18 公司信息****19 参考资料****20 修订记录**



## 1 The Board

### 1.1 Application Examples

Arduino Nano is the first embedded microcontroller in the Nano series with minimum functionalities, designed for mini projects from the maker community. With a large number of input/output pins gives the advantage of utilizing several serial communications like UART, SPI and I2C. The hardware is compatible with Arduino IDE, Arduino CLI and Cloud Editor.

**Security:** The high-performance and low-power capabilities gives the chance to develop security based applications like access control systems using fingerprint sensors. The flexibility to interface sensors and external devices using serial communication has improved the scope of utility.

**Environmental:** The low-power feature of the microcontroller and the power supply options for the board has enhanced the ability to implement remote IoT projects related to environmental issues.

**Robotics:** Robotics has always been the favorite area of exploration for the Maker community and with this tiny embedded hardware you can now create complex and advanced robotic applications.

### 1.2 Accessories

### 1.3 Related Products

- Arduino® Nano 33 BLE (SKU: ABX00030)
- Arduino® 33 IoT (SKU: ABX00027)
- Arduino® Micro (SKU: A000093)

## 2 Ratings

### 2.1 Recommended Operating Conditions

Symbol	Description	Min	Max
	Conservative thermal limits for the whole board:	-40 °C	85 °C

### 2.2 Power Consumption

Symbol	Description	Min	Typ	Max	Unit
USB VCC	Input supply from USB		TBC		mW
VIN	Input from VIN pad		TBC		mW

## 3 Functional Overview

### 3.1 Block Diagram

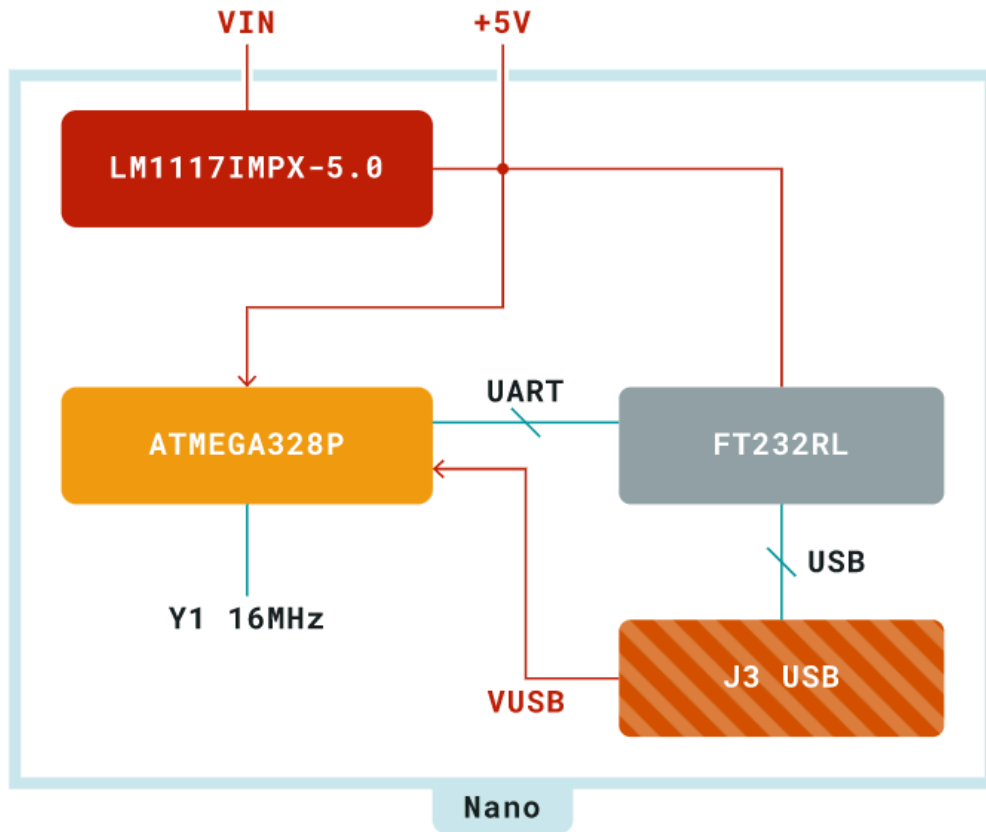

- |                |                    |
|----------------|--------------------|
| Power          | Microcontroller    |
| LED            | Data Communication |
| Internal Parts | Connectors         |

Block Diagram of Arduino Nano



## 4 Board Operation

### 4.1 Getting Started - IDE

If you want to program your Nano while offline you need to install the Arduino Desktop IDE **[1]** To connect the Nano to your computer, you'll need a Micro-B USB cable. This also provides power to the board, as indicated by the LED.

### 4.2 Getting Started - Arduino Cloud Editor

All Arduino boards, including this one, work out-of-the-box on the Arduino Cloud Editor **[2]**, by just installing a simple plugin.

The Arduino Cloud Editor is hosted online, therefore it will always be up-to-date with the latest features and support for all boards. Follow **[3]** to start coding on the browser and upload your sketches onto your board.

### 4.3 Sample Sketches

Sample sketches for the board can be found either in the "Examples" menu in the Arduino IDE or in Arduino Documentation **[4]**.

### 4.4 Online Resources

Now that you have gone through the basics of what you can do with the board you can explore the endless possibilities it provides by checking exciting projects on Arduino Project Hub **[5]**, the Arduino Library Reference **[6]** and the online store **[7]** where you will be able to complement your board with sensors, actuators and more.

## 5 Connector Pinouts



**ARDUINO  
NANO**

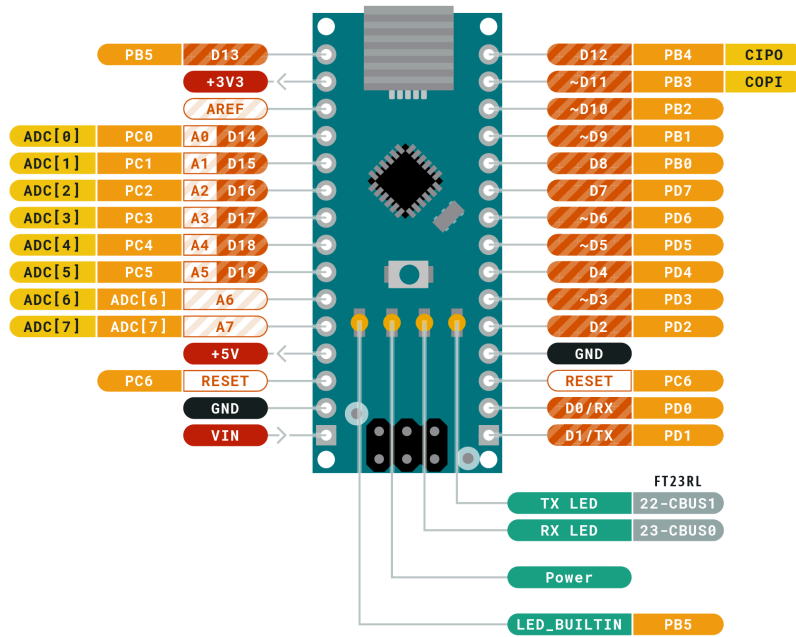

Ground	Internal Pin	Digital Pin	Microcontroller's Port
Power	SWD Pin	Analog Pin	
LED	Other Pin	Default	

ARDUINO.CC

This work is licensed under the Creative Commons Attribution-ShareAlike 4.0 International License. To view a copy of this license, visit <http://creativecommons.org/licenses/by-sa/4.0/> or send a letter to Creative Commons, PO Box 1886, Mountain View, CA 94042, USA.

Power Tree of Arduino Nano



## 5.1 Analog

Pin	Function	Type	Description
1	+3V3	Power	5V USB Power
2	A0	Analog	Analog input 0 /GPIO
3	A1	Analog	Analog input 1 /GPIO
4	A2	Analog	Analog input 2 /GPIO
5	A3	Analog	Analog input 3 /GPIO
6	A4	Analog	Analog input 4 /GPIO
7	A5	Analog	Analog input 5 /GPIO
8	A6	Analog	Analog input 6 /GPIO
9	A7	Analog	Analog input 7 /GPIO
10	+5V	Power	+5V Power Rail
11	Reset	Reset	Reset
12	GND	Power	Ground
12	VIN	Power	Voltage Input

## 5.2 Digital

Pin	Function	Type	Description
1	D1/TX1	Digital	Digital Input 1 /GPIO
2	D0/RX0	Digital	Digital Input 0 /GPIO
3	D2	Digital	Digital Input 2 /GPIO
4	D3	Digital	Digital Input 3 /GPIO
5	D4	Digital	Digital Input 4 /GPIO
6	D5	Digital	Digital Input 5 /GPIO
7	D6	Digital	Digital Input 6 /GPIO
8	D7	Digital	Digital Input 7 /GPIO
9	D8	Digital	Digital Input 8 /GPIO
10	D9	Digital	Digital Input 9 /GPIO
11	D10	Digital	Digital Input 10 /GPIO
12	D11	Digital	Digital Input 11 /GPIO
13	D12	Digital	Digital Input 12 /GPIO
14	D13	Digital	Digital Input 13 /GPIO
15	Reset	Reset	Reset
16	GND	Power	Ground

### 5.3 ATmega328

Pin	Function	Type	Description
1	PB0	Internal	Serial Wire Debug
2	PB1	Internal	Serial Wire Debug
3	PB2	Internal	Serial Wire Debug
4	PB3	Internal	Serial Wire Debug
5	PB4	Internal	Serial Wire Debug
6	PB5	Internal	Serial Wire Debug

## 6 Mechanical Information

ARDUINO  
NANO  
Size

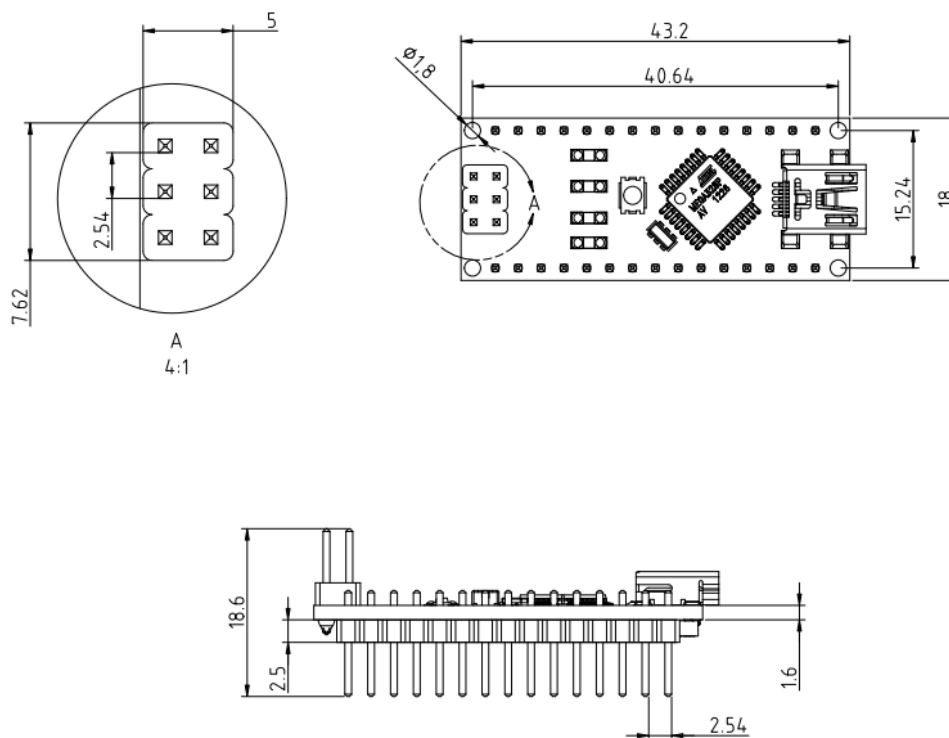

2020/11/19

Mechanical dimensions of Arduino Nano

## 7 Certifications

### 7.1 Declaration of Conformity CE DoC (EU)

We declare under our sole responsibility that the products above are in conformity with the essential requirements of the following EU Directives and therefore qualify for free movement within markets comprising the European Union (EU) and European Economic Area (EEA).

### 7.2 Declaration of Conformity to EU RoHS & REACH 211 01/19/2021

Arduino boards are in compliance with RoHS 2 Directive 2011/65/EU of the European Parliament and RoHS 3 Directive 2015/863/EU of the Council of 4 June 2015 on the restriction of the use of certain hazardous substances in electrical and electronic equipment.

Substance	Maximum Limit (ppm)
Lead (Pb)	1000
Cadmium (Cd)	100
Mercury (Hg)	1000
Hexavalent Chromium (Cr6+)	1000
Poly Brominated Biphenyls (PBB)	1000
Poly Brominated Diphenyl ethers (PBDE)	1000
Bis(2-Ethylhexyl} phthalate (DEHP)	1000
Benzyl butyl phthalate (BBP)	1000
Dibutyl phthalate (DBP)	1000
Diisobutyl phthalate (DIBP)	1000

Exemptions : No exemptions are claimed.

Arduino Boards are fully compliant with the related requirements of European Union Regulation (EC) 1907 /2006 concerning the Registration, Evaluation, Authorization and Restriction of Chemicals (REACH). We declare none of the SVHCs (<https://echa.europa.eu/web/guest/candidate-list-table>), the Candidate List of Substances of Very High Concern for authorization currently released by ECHA, is present in all products (and also package) in quantities totaling in a concentration equal or above 0.1%. To the best of our knowledge, we also declare that our products do not contain any of the substances listed on the "Authorization List" (Annex XIV of the REACH regulations) and Substances of Very High Concern (SVHC) in any significant amounts as specified by the Annex XVII of Candidate list published by ECHA (European Chemical Agency) 1907 /2006/EC.

### 7.3 Conflict Minerals Declaration

As a global supplier of electronic and electrical components, Arduino is aware of our obligations with regards to laws and regulations regarding Conflict Minerals, specifically the Dodd-Frank Wall Street Reform and Consumer Protection Act, Section 1502. Arduino does not directly source or process conflict minerals such as Tin, Tantalum, Tungsten, or Gold. Conflict minerals are contained in our products in the form of solder, or as a component in metal alloys. As part of our reasonable due diligence Arduino has contacted component suppliers within our supply chain to verify their continued compliance with the regulations. Based on the information received thus far we declare that our products contain Conflict Minerals sourced from conflict-free areas.

### 7.4 FCC Caution

Any Changes or modifications not expressly approved by the party responsible for compliance could void the user's authority to operate the equipment.

This device complies with part 15 of the FCC Rules. Operation is subject to the following two conditions:

- (1) This device may not cause harmful interference
- (2) this device must accept any interference received, including interference that may cause undesired operation.

#### **FCC RF Radiation Exposure Statement:**

1. This Transmitter must not be co-located or operating in conjunction with any other antenna or transmitter.
2. This equipment complies with RF radiation exposure limits set forth for an uncontrolled environment.
3. This equipment should be installed and operated with minimum distance 20cm between the radiator & your body.

English: User manuals for license-exempt radio apparatus shall contain the following or equivalent notice in a conspicuous location in the user manual or alternatively on the device or both. This device complies with Industry Canada license-exempt RSS standard(s). Operation is subject to the following two conditions:

- (1) this device may not cause interference
- (2) this device must accept any interference, including interference that may cause undesired operation of the device.

French: Le présent appareil est conforme aux CNR d'Industrie Canada applicables aux appareils radio exempts de licence. L'exploitation est autorisée aux deux conditions suivantes :

- (1) l' appareil n' doit pas produire de brouillage
- (2) l' utilisateur de l' appareil doit accepter tout brouillage radioélectrique subi, même si le brouillage est susceptible d' en compromettre le fonctionnement.

#### **IC SAR Warning:**

English This equipment should be installed and operated with minimum distance 20 cm between the radiator and your body.

French: Lors de l' installation et de l' exploitation de ce dispositif, la distance entre le radiateur et le corps est d' au moins 20 cm.



**Important:** The operating temperature of the EUT can't exceed 80°C and shouldn't be lower than -20°C.

Hereby, Arduino S.r.l. declares that this product is in compliance with essential requirements and other relevant provisions of Directive 2014/53/EU. This product is allowed to be used in all EU member states.

## 8 Company Information

<b>Company name</b>	<b>Arduino S.r.l.</b>
Company Address	Via Andrea Appiani 25, 20900 MONZA MB, Italy

## 9 Reference Documentation

Ref	Link
Arduino IDE (Desktop)	<a href="https://www.arduino.cc/en/software">https://www.arduino.cc/en/software</a>
Arduino Cloud Editor	<a href="https://create.arduino.cc/editor">https://create.arduino.cc/editor</a>
Arduino Cloud Editor - Getting Started	<a href="https://docs.arduino.cc/arduino-cloud/guides/editor/">https://docs.arduino.cc/arduino-cloud/guides/editor/</a>
Arduino Documentation	<a href="https://docs.arduino.cc/hardware/nano">https://docs.arduino.cc/hardware/nano</a>
Arduino Project Hub	<a href="https://create.arduino.cc/projecthub?by=part&amp;part_id=11332&amp;sort=trending">https://create.arduino.cc/projecthub?by=part&amp;part_id=11332&amp;sort=trending</a>
Library Reference	<a href="https://www.arduino.cc/reference/en/libraries/">https://www.arduino.cc/reference/en/libraries/</a>
Online Store	<a href="https://store.arduino.cc/">https://store.arduino.cc/</a>

## 10 Revision History

Date	Revision	Changes
25/04/2024	3	Updated link to new Cloud Editor
03/08/2022	2	Reference documentation links updates
12/04/2022	1	First Release

## 中文 (ZH)

### 描述

**Arduino® Nano**是一款智能开发板，旨在以最小的尺寸构建更快的原型。Arduino Nano 是 Nano 系列中最早的一款产品，可为您的试验电路板友好型应用提供足够的接口。该开发板的核心是**ATmega328 微控制器**，时钟频率为 16 MHz，功能与 Arduino Duemilanove 大致相同。该电路板提供 20 个数字输入/输出引脚、8 个模拟引脚和一个微型 USB 端口。

### 目标领域：

创客、安全、环境、机器人和控制系统

### 特点

- **ATmega328 微控制器**
  - 高性能低功耗 8 位处理器
  - 在 16 MHz 时钟频率下实现高达 16 MIPS 的性能
  - 32 kB，其中 2 kB 用于引导加载程序
  - 2 kB 内部 SRAM
  - 1 kB EEPROM
  - 32 x 8 通用工作寄存器
  - 带有独立振荡器的实时计数器
  - 6 通道 PWM
  - 可编程串行 USART
  - 主/从 SPI 串行接口
- **电源**
  - Mini-B USB 连接
  - 7-15V 非稳压外部电源（引脚 30）
  - 5V 稳压外部电源（引脚 27）
- **休眠模式**
  - 空闲
  - ADC 降噪
  - 节能
  - 掉电
  - 待机
  - 延长待机
- **输入/输出**
  - 20 数字
  - 8 模拟
  - 6 PWM 输出

## 目录

### 11 电路板简介

#### 11.1 应用示例

Arduino Nano 是 Nano 系列中首款嵌入式微控制器，具有最基本的功能，专为创客社区的微型项目而设计。它拥有大量输入/输出引脚，可利用 UART、SPI 和 I2C 等多种串行通信。硬件兼容 Arduino IDE、Arduino CLI 和网络编辑器。

**安全性：**高性能和低功耗的特点为开发基于安全性的应用提供了机会，如使用指纹传感器的门禁系统。利用串行通信接口连接传感器和外部设备的灵活性扩大了实用范围。

**环境：**微控制器的低功耗特性和电路板的电源选项增强了实施与环境问题有关的远程物联网项目的能力。

**机器人技术：**机器人技术一直是创客社区最喜欢探索的领域，有了这个微型嵌入式硬件，您现在可以创建复杂而高级的机器人应用程序。

#### 11.2 配件

#### 11.3 相关产品

- Arduino Nano 33 BLE
- Arduino 33 IoT
- Arduino Micro

### 12 额定值

#### 12.1 建议运行条件

符号	描述	最小值	最大值
	整个电路板的保守温度极限值：	-40 °C	85 °C

## 12.2 功耗

符号	描述	最小值	典型值	最大值	单位
USB VCC	USB 电源输入		TBC		mW
VIN	来自 VIN 焊盘的输入		TBC		mW

## 13 功能概述

### 13.1 方框图

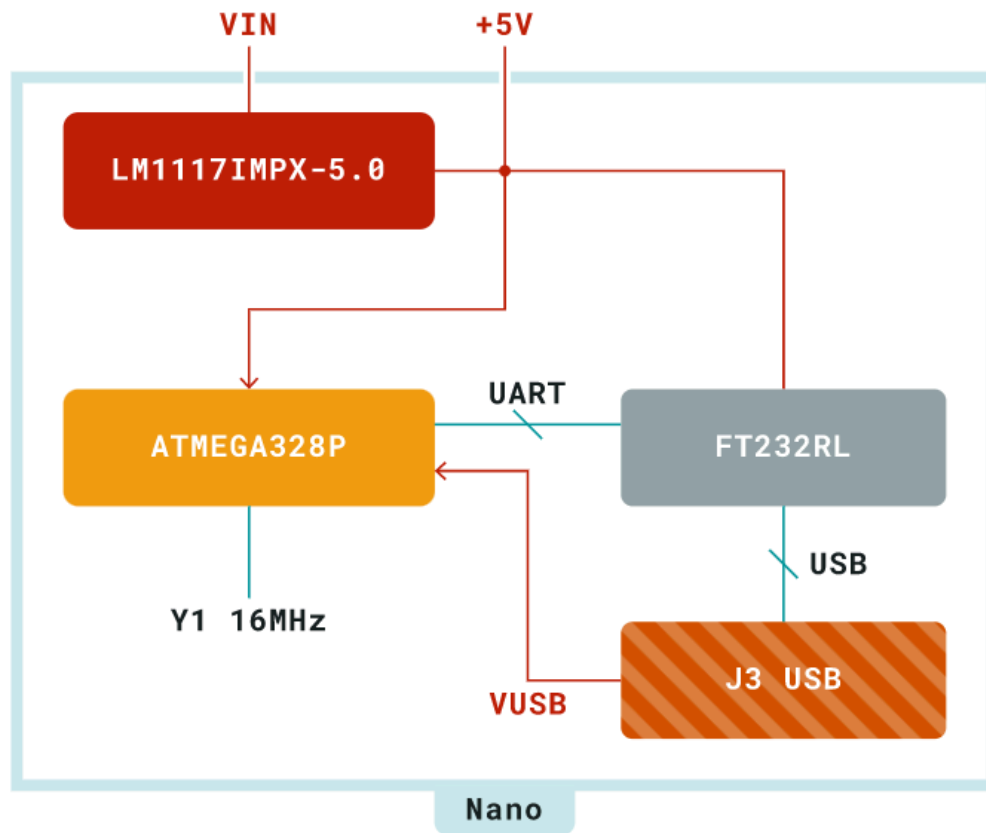

Arduino Nano 方框图

## 13.2 处理器

Arduino Nano v3.3 电路板的主处理器是高性能、低功耗的 8 位 ATmega328 微控制器，其时钟频率为 16 MHz。芯片支持 UART TTL (5V)、I2C (TWI) 和 SPI，能够通过串行通信接口连接外部设备。Arduino Nano 可通过 Arduino 软件进行编程，降低了新用户的入门门槛。最小尺寸的嵌入式硬件使其成为创客社区试验电路板友好型项目的最佳选择。

## 13.3 电源树

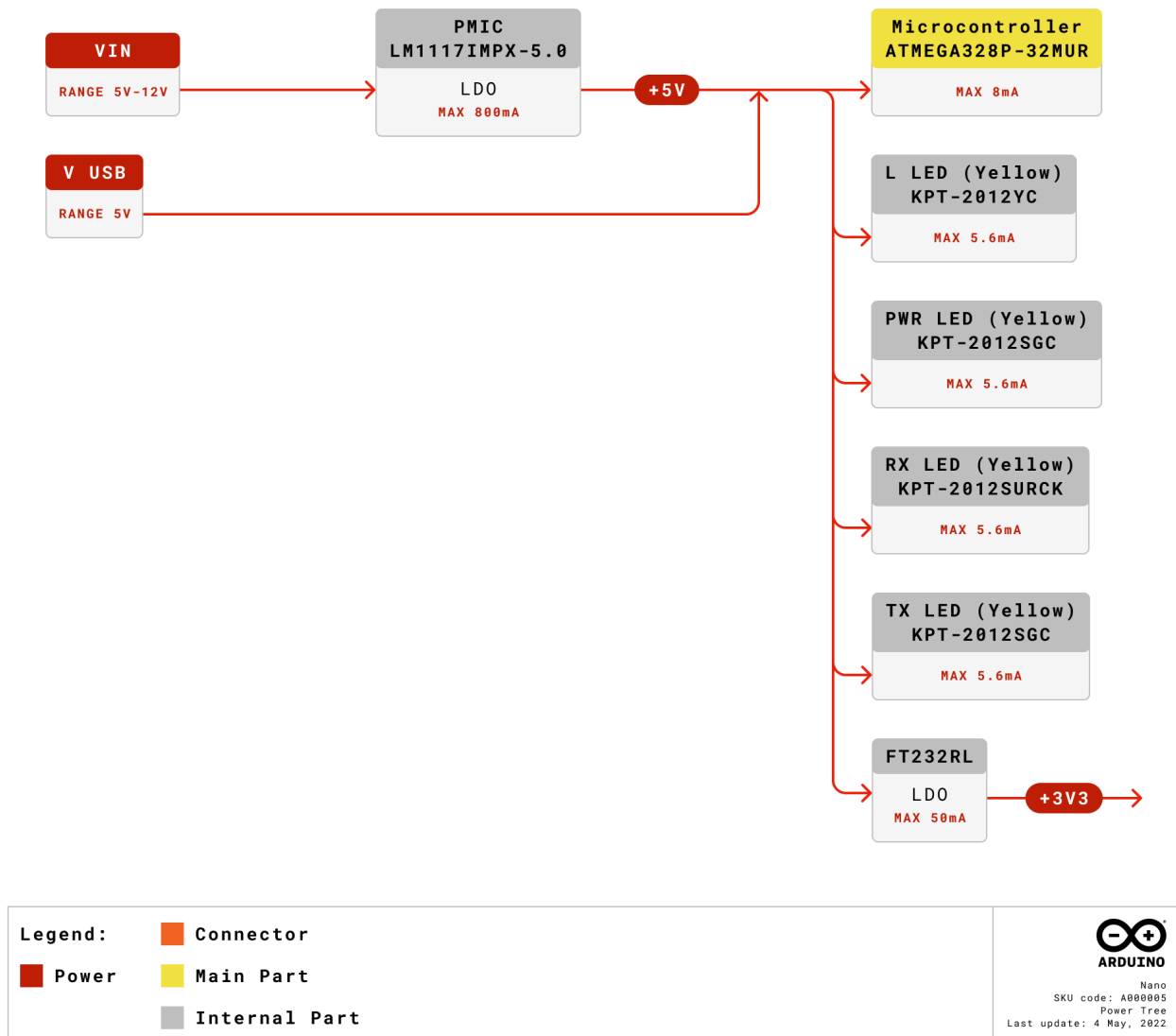

Arduino Nano 电源树

Arduino Nano 可以通过 USB 端口或 VIN 供电。VIN 的输入电源由一个 LDO 进行调节，因此电源电压限制在 5V，使电路板在最佳状态下运行。另外还有一个稳压器，可将电压限制在 3.3V，为需要低电压的元件供电。

## 14 电路板操作

### 14.1 入门指南 - IDE

如需在离线状态下对 Arduino® Nano 进行编程，则需要安装 Arduino® Desktop IDE [1] 若要将 Arduino Uno 连接到计算机，则需要使用 Micro-B USB 电缆。如 LED 指示灯所示，该电缆还可以为电路板供电。

### 14.2 入门指南 - Arduino Cloud Editor

包括本电路板在内的所有 Arduino® 电路板都可以在 Arduino Cloud Editor [2] 上开箱即用，只需安装一个简单的插件即可。**Arduino Cloud Editor 是在线托管的，因此它将始终提供最新功能并支持所有电路板。**接下来 [3] 开始在浏览器上编码并将程序上传到您的电路板上。

### 14.3 示例程序

Arduino® 的示例程序可以在 Arduino® IDE 的“示例”菜单或 Arduino 网站 [4] 的“文档”部分找到

### 14.4 在线资源

现在，您已经了解该电路板的基本功能，就可以通过查看 Arduino Project Hub [5]、Arduino® Library Reference [6] 和在线商店 [7] 上的精彩项目来探索它所提供的无限可能性；在这些项目中，您可以为电路板配备传感器、执行器等。



## 15.1 模拟

引脚	功能	类型	描述
1	+3V3	电源	5V USB 电源
2	A0	模拟	模拟输入0 / GPIO
3	A1	模拟	模拟输入1 / GPIO
4	A2	模拟	模拟输入2 / GPIO
5	A3	模拟	模拟输入3 / GPIO
6	A4	模拟	模拟输入4 / GPIO
7	A5	模拟	模拟输入5 / GPIO
8	A6	模拟	模拟输入6 / GPIO
9	A7	模拟	模拟输入7 / GPIO
10	+5V	电源	+5V 电源轨
11	复位	复位	复位
12	GND	电源	接地
12	VIN	电源	电压输入

## 15.2 数字

引脚	功能	类型	描述
1	D1/TX1	数字	数字输入 1/GPIO
2	D0/RX0	数字	数字输入 0/GPIO
3	D2	数字	数字输入 2/GPIO
4	D3	数字	数字输入 3/GPIO
5	D4	数字	数字输入 4/GPIO
6	D5	数字	数字输入 5/GPIO
7	D6	数字	数字输入 6/GPIO
8	D7	数字	数字输入 7/GPIO
9	D8	数字	数字输入 8/GPIO
10	D9	数字	数字输入 9/GPIO
11	D10	数字	数字输入 10/GPIO
12	D11	数字	数字输入 11/GPIO
13	D12	数字	数字输入 12/GPIO
14	D13	数字	数字输入 13/GPIO
15	复位	复位	复位
16	GND	电源	接地

### 15.3 ATmega328

引脚	功能	类型	描述
1	PB0	内部	串行线调试
2	PB1	内部	串行线调试
3	PB2	内部	串行线调试
4	PB3	内部	串行线调试
5	PB4	内部	串行线调试
6	PB5	内部	串行线调试

## 16 机械层信息

ARDUINO  
NANO  
Size

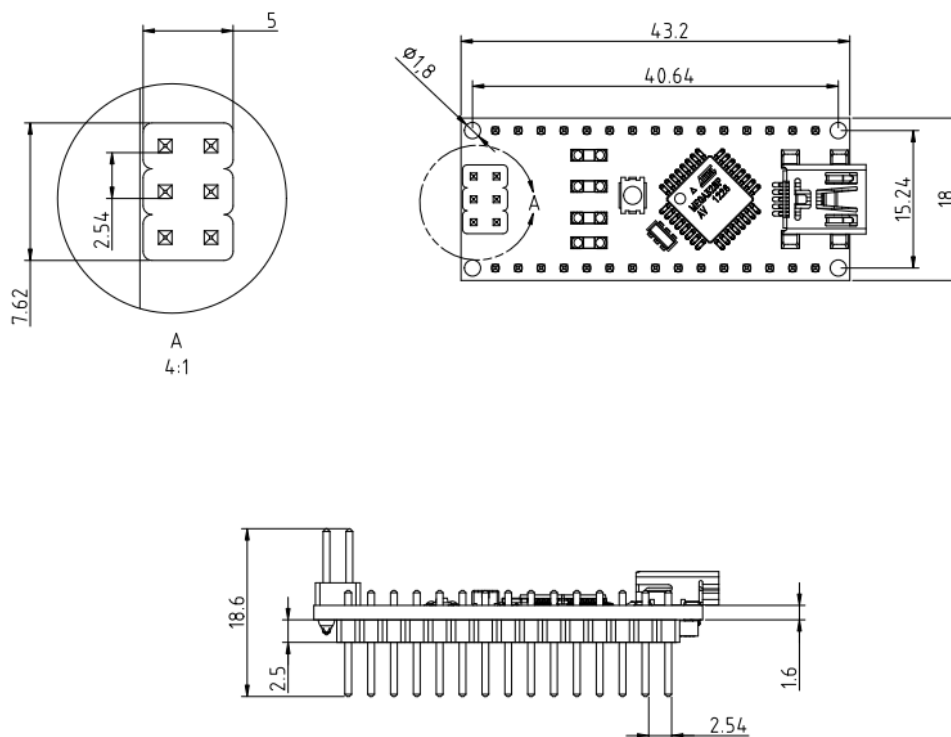

2020/11/19

Arduino Nano 机械尺寸

## 17 认证

### 17.1 符合性声明 CE DoC (欧盟)

我们在此郑重声明，上述产品符合以下欧盟指令的基本要求，因此有资格在包括欧盟（EU）和欧洲经济区（EEA）在内的市场内自由流通。

### 17.2 声明符合欧盟 RoHS 和 REACH 211 01/19/2021

Arduino 电路板符合欧洲议会关于限制在电子电气设备中使用某些有害物质的 RoHS 2 指令 2011/65/EU 和欧盟理事会于 2015 年 6 月 4 日颁布的关于限制在电子电气设备中使用某些有害物质的 RoHS 3 指令 2015/863/EU。

物质	最大限值 (ppm)
铅 (Pb)	1000
镉 (Cd)	100
汞 (Hg)	1000
六价铬 (Cr6+)	1000
多溴联苯 (PBB)	1000
多溴联苯醚 (PBDE)	1000
邻苯二甲酸二(2-乙基己)酯 (DEHP)	1000
邻苯二甲酸丁苄酯 (BBP)	1000
邻苯二甲酸二丁酯 (DBP)	1000
邻苯二甲酸二异丁酯 (DIBP)	1000

豁免：未申请任何豁免。

Arduino 电路板完全符合欧盟法规 (EC) 1907/2006 中关于化学品注册、评估、许可和限制 (REACH) 的相关要求。我们声明，所有产品（包括包装）中的 SVHC (<https://echa.europa.eu/web/guest/candidate-list-table>)，（欧洲化学品管理局目前发布的《高度关注物质候选授权清单》）含量总浓度均未超过 0.1%。据我们所知，我们还声明，我们的产品不含 ECHA（欧洲化学品管理局）1907/2006/EC 公布的候选清单附件 XVII 中规定的“授权清单”（REACH 法规附件 XIV）和高度关注物质 (SVHC) 所列的任何物质。

### 17.3 冲突矿产声明

作为电子和电气元件的全球供应商，Arduino 意识到我们有义务遵守有关冲突矿产的法律法规，特别是《多德-弗兰克华尔街改革与消费者保护法》第 1502 条。Arduino 不直接采购或加工锡、钽、钨或金等冲突矿物。冲突矿物以焊料的形式或作为金属合金的组成部分存在于我们的产品中。作为我们合理尽职调查的一部分，Arduino 已联系供应链中的元件供应商，以核实他们是否始终遵守法规的相关规定。根据迄今收到的信息，我们声明我们的产品中含有来自非冲突地区的冲突矿物。

### 17.4 FCC 警告

任何未经合规性负责方明确批准的更改或修改都可能导致用户无权操作设备。

本设备符合 FCC 规则第 15 部分的规定。操作须满足以下两个条件：

- (1) 此设备不会造成有害干扰
- (2) 此设备必须接受接收到的任何干扰，包括可能导致不良操作的干扰。

#### FCC 射频辐射暴露声明:

1. 此发射器不得与任何其他天线或发射器放在同一位置或同时运行。
2. 此设备符合为非受控环境规定的射频辐射暴露限值。
3. 安装和操作本设备时，辐射源与您的身体之间至少应保持 20 厘米的距离。

English: User manuals for license-exempt radio apparatus shall contain the following or equivalent notice in a conspicuous location in the user manual or alternatively on the device or both. This device complies with Industry Canada license-exempt RSS standard(s). Operation is subject to the following two conditions:

- (1) this device may not cause interference
- (2) this device must accept any interference, including interference that may cause undesired operation of the device.

French: Le présent appareil est conforme aux CNR d'Industrie Canada applicables aux appareils radio exempts de licence. L'exploitation est autorisée aux deux conditions suivantes :

- (1) l'appareil n' doit pas produire de brouillage
- (2) l'utilisateur de l'appareil doit accepter tout brouillage radioélectrique subi, même si le brouillage est susceptible d'en compromettre le fonctionnement.

#### IC SAR警告:

English This equipment should be installed and operated with a minimum distance of 20 cm between the radiator and your body.

French: Lors de l' installation et de l' exploitation de ce dispositif, la distance entre le radiateur et le corps est d' au moins 20 cm.

**重要提示:** EUT 的工作温度不能超过 80°C，也不能低于 -20°C。

Arduino S.r.l. 特此声明，本产品符合 2014/53/EU 指令的基本要求和相关规定。本产品允许在所有欧盟成员国使用。

## 18 公司信息

公司名称	Arduino S.r.l.
公司地址	Via Andrea Appiani 25, 20900 MONZA MB, Italy

## 19 参考资料

参考资料	链接
Arduino IDE (Desktop)	<a href="https://www.arduino.cc/en/software">https://www.arduino.cc/en/software</a>
Arduino IDE (Cloud)	<a href="https://create.arduino.cc/editor">https://create.arduino.cc/editor</a>
Cloud IDE 入门指南	<a href="https://create.arduino.cc/projecthub/Arduino_Genuino/getting-started-with-arduino-web-editor-4b3e4a">https://create.arduino.cc/projecthub/Arduino_Genuino/getting-started-with-arduino-web-editor-4b3e4a</a>
Arduino 文档	<a href="https://docs.arduino.cc/hardware/nano">https://docs.arduino.cc/hardware/nano</a>
Arduino Project Hub	<a href="https://create.arduino.cc/projecthub?by=part&amp;part_id=11332&amp;sort=trending">https://create.arduino.cc/projecthub?by=part&amp;part_id=11332&amp;sort=trending</a>
库参考	<a href="https://www.arduino.cc/reference/en/libraries/">https://www.arduino.cc/reference/en/libraries/</a>
在线商店	<a href="https://store.arduino.cc/">https://store.arduino.cc/</a>

## 20 修订记录

日期	版次	变更
2022/03/08	2	参考资料链接更新
2022/12/04	1	首次发布